

GAT'R JAW™ SPREADERS

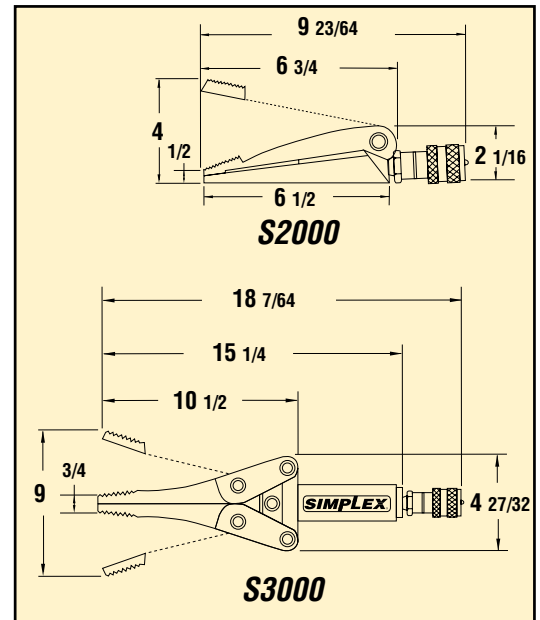

- 2 Models
- High flow quality couplers.
- Spring return for easy operation.
- Narrow closed ends.
- All metal construction.



Hydraulic Spreaders 1 & 1 1/2 Ton Capacities

Model Number	Cap. (tons)	Pressure @ Capacity (psi)	Oil Capacity Required (cu. in.)	Weight (lbs)	Suggested Hand Pump
S2000	1	10,000	.8	7	P42
S3000	1.5		5.5	16	

5 TON HYDRAULIC SPREADER

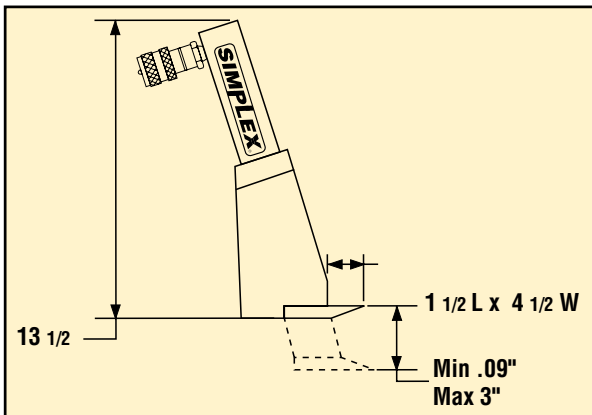

- 5 tons of spreading force.
- 1/8" through 3" spreading capability.
- Jaws open parallel.
- Will not drift.
- All metal construction.



Hydraulic Flange Spreader 5 Ton Capacity

Model Number	Cap. (tons)	Pres. @ Cap. (psi)	Oil Cap. Req. (cu. in.)	Weight (lbs)	Spread		Suggested Hand Pump
					Min. (in.)	Max. (in.)	
SF5	5	10,000	5	17	.09	3	P22

10 TON SPREADER/PULLER



Mechanical Spreader/Puller 10 Ton Capacity

Model Number	Cap. (tons)	Offset Cap. (tons)	Travel (in.)	Screw Dia. (in.)	Length (in)	Wt. (lbs)	Steel Lever Bars			
							Order Number	Length (in)	Dia (in)	Wgt. (lbs)
610	10	2	4 1/2	1 1/4	10	13	10621	24	3/4	4

